

PAXTON PRODUCTS

Air Knives

Common Applications

■ Drying Applications

- ▶ Food Packaging
- ▶ Bottles and Cans
- ▶ PC Boards
- ▶ Machined Parts
- ▶ Coating Control
- ▶ Glass & Plastic Sheets
- ▶ Rolled Sheets
- ▶ Multi-strand Metal & Plastic

■ Blow-off Applications

- ▶ Pharmaceuticals
- ▶ Textiles
- ▶ Fabricated Parts
- ▶ Debris Blow-off
- ▶ Conveyor Belt Cleaning & Drying

Paxton Aluminum and Stainless Steel Air Kinves have been designed and engineered to provide the maximum efficiency available for high velocity air knife drying and blow-off applications.



Aluminum Air Knives, weighing less than three pounds per linear foot (stainless steel models just under four pounds), are easily mounted to any configuration necessary. The Air Knives feature a continuous, uninterrupted, air slot design (with a standard .055" gap setting) which will ensure that you will receive high velocity air completely across the project area.

Performance Specifications in CFM(Cubic Feet per Minute).

Model Number	Effective Length	Pressure (inches of water column)			
		40" H ₂ O	50" H ₂ O	60" H ₂ O	70" H ₂ O
8001789-6	6"	57	63	68	73
8001789-12	12"	113	125	136	146
8001789-18	18"	169	188	204	219
8001789-24	24"	226	250	272	292
8001789-30	30"	282	313	340	365
8001789-36	36"	338	375	408	438
Velocity (FPM)		24,558	27,259	29,650	31,804

*Air knife performance specifications are based on operation at 14.7 PSIA, 68° F ambient at sea level, with a .055" gap setting.

TW Air Management

10125 Carver Road
Cincinnati, Ohio 45242 USA

(800) 959-8884 Toll Free
(513) 891-7474 Phone
(513) 891-7485 Fax
www.paxtonproducts.com

PAXTON PRODUCTS

OVERALL DIMENSIONS

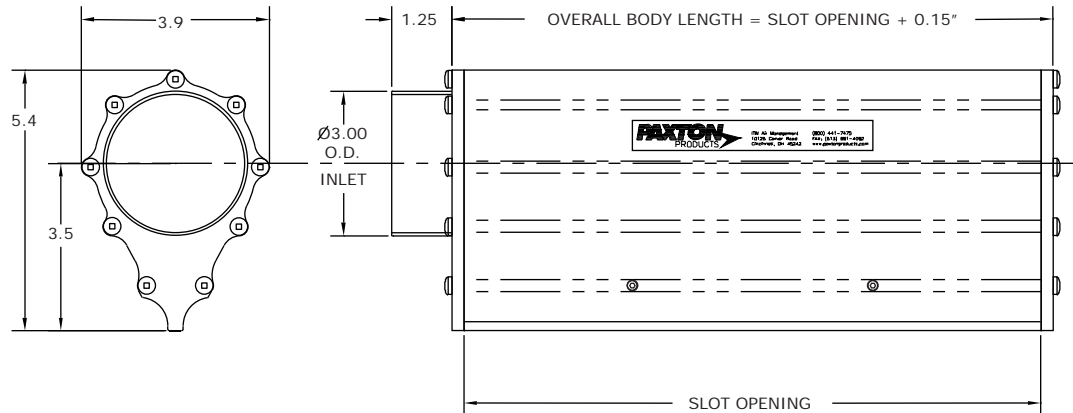

OPTIONAL EQUIPMENT

Mounting Plates

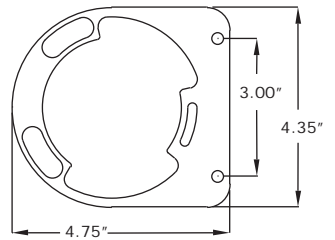

PART NUMBER: 8003085

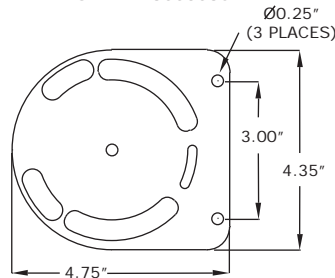

PART NUMBER: 8003086

Mounting Rod Kit

MOUNTING PLATES SUPPLIED AS A SEPERATE KIT

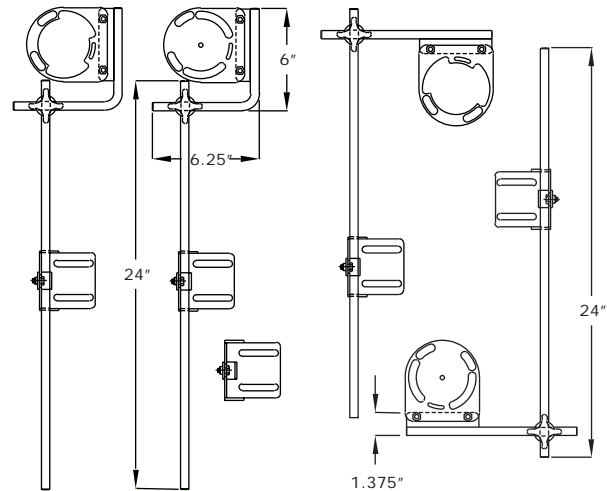

MODEL 8005210-24

MODEL 8005211-24

ADDITIONAL EQUIPMENT

- ▶ Blower Systems
- ▶ Blower Enclosures
- ▶ Aluminum Adaptors
- ▶ Dividers
- ▶ Stainless Steel Air Knives
- ▶ Adjustable Valves
- ▶ Hoses
- ▶ Stainless Steel Elbows

TW Air Management

10125 Carver Road • Cincinnati, Ohio 45242 USA
 (800) 959-8884 Toll Free • (513) 891-7474 Phone • (513) 891-4092 Fax
 www.paxtonproducts.com